

New!

MILLER Fusion™ Roof Anchor Post



FREQUENTLY ASKED QUESTIONS

Q1: What is the new Miller Fusion Roof Anchor Post?

A1: The new Miller Fusion Roof Anchor Post provides a single point anchorage for workers conducting maintenance on industrial-style roofs. It adapts to a wide range of roof designs with its innovative base plate engineered for temporary or permanent installation to the roof surface. Once installed, a dependable fall protection connection is established. In the event of a fall, forces are reduced with its unique energy-absorbing, load distribution system while the base maintains a secure connection to the structure.

Q2: How does the Miller Fusion reduce the forces applied to the roof structure?

A2: The patent pending Miller Fusion Roof Anchor Post maintains a rigid, elevated anchorage connection until forces during a fall exceed a predetermined value. When the force threshold is exceeded, the integral sacrificial element deploys allowing the energy absorber to elongate and the post to reorient in the direction of the fall. The three functions of shock absorption, tipping and reorientation not only absorb energy but also lower the anchorage connection close to the roof surface. With the anchorage connection in this lower position, the high fall forces can be better distributed to utilize the strength of the entire roof surface. This is a critical factor with modern, lightweight roofing.



Q3: Why is the Miller Fusion a better solution than traditional-style posts constructed of heavy steel?

A3: Traditional roof anchorage posts are rigid, heavy posts that require major structural modifications and reinforcement for installation. In roofing applications, the fall protection connection point is generally close to foot level of the worker. With a low connection, freefall may be increased which can also increase the force applied to the connection point of the post. With a higher post, freefall may be decreased but the effect of the bending moment will dramatically increase the force applied at the base of the post. This is why installation of a rigid post requires opening up the roof to install the post to structural beams with robust connections. Once a traditional post has been installed, the roof must be repaired.

Q4: What are the primary benefits of installing the Miller Fusion versus a traditional-style post?

A4: The Miller Fusion offers many benefits over a traditional-style post. These benefits include:

- **Attachment of the Miller Fusion to the roof surface is quick and easy reducing installation time by more than 50%! –** Since all models are installed from the roof's surface, there is no need to open up the roof to connect to the underlying structural members. This eliminates the need for roof repair.
- **Installation cost is minimized –** Quick installation and avoidance of roof repair equates to reduced labor cost.
- **Installation is less invasive –** The less you have to penetrate the roof, the more assured you are to preserve the integrity of the original roof installation. This minimizes the chance for leaks and helps preserve the warranty of your roof.

Q5: What types of roofing does the Miller Fusion accommodate?

A5: With ten models available, the versatile design of Miller Fusion Roof Post can accommodate most industrial roof designs including standing seam, membrane, built-up, metal sheathing, trapezoidal, concrete and wood.

Fusion Roof Anchor Post

SKU	Description	Designed to Accommodate
■ STANDING SEAM ROOFING – Includes post with base and standing seam clamping assembly kit		
X10000	Small base	Standing seam spacing from 11.75 in. (298 mm) to 17 in. (432 mm)
X10001	Large base	Standing seam spacing from 11.75 in. (298 mm) to 21.25 in. (540 mm)
X10002	Large base & extension bars	Standing seam spacing from 11.75 in. (298 mm) to 24 in. (610 mm)
■ METAL SHEATHING ROOFING – Includes post with base and rivet kit with sealing washers and mastic tape		
X10010	Small base	Metal sheathing w/minimum thickness of 24 gauge (0.024 in. [0.61 mm])
X10011	Large base	Metal sheathing w/minimum thickness of 24 gauge (0.024 in. [0.61 mm]). Trapezoidal spacing of 8 in. (203 mm) to 20 in. (508 mm) in one-inch (25.4 mm) increments.
■ MEMBRANE / BUILT-UP ROOFING – Includes post with base and toggle bolt kit		
X10030	Up to 5.5 in. (140 mm) thickness	Fastens through membrane, insulation & into metal sheathing, wood sheathing or concrete with a combined thickness of up to 5.5 in. (140 mm)
X10031	> 5.5 in. (140 mm) & up to 10.5 in. (267 mm) thickness	Fastens through membrane, insulation & into metal sheathing, wood sheathing or concrete with a combined thickness of > 5.5 in. (140 mm) up to 10.5 in. (267 mm)
■ WOOD SHEATHING (TEMPORARY INSTALLATIONS ONLY) – Includes post with base and lag screw kit		
X10040	Wood sheathing	Plywood with minimum thickness of 5/8-in. (15.9 mm) CDX
■ CONCRETE ROOFING – Includes post with base and concrete expansion bolt anchor kit		
X10050	Concrete	Concrete decking with minimum thickness of 6.5 in. (165 mm) & minimum concrete compressive strength of 3000 PSI (20.7 MPa)
■ MULTI-PURPOSE METAL SHEATHING, WOOD AND CONCRETE ROOFING (NO HARDWARE INCLUDED) – Includes post with base. Hardware selection is based on the application. See instruction manual for hardware specifications.		
X10020	Metal sheathing, wood or concrete	<ul style="list-style-type: none"> • Metal sheathing w/minimum thickness of 24 gauge (0.024 in. [0.61 mm]) • Trapezoidal spacing of 8 in. (203 mm) to 20 in. (508 mm) in one-inch (25.4 mm) increments. • Plywood with minimum thickness of 5/8-in. (15.9 mm) CDX • Concrete decking with minimum thickness of 6.5 in. (165 mm) & minimum concrete compressive strength of 3000 PSI (20.7 MPa)

Q6: What are some of the unique, key features of individual Fusion designs?

A6: The Miller Fusion offers many unique key features.

Standing Seam Design



- Designed to allow clamping feet to be pre-installed to the base
- Model X100002, accommodates standing seam spacing up to 24-inches (609 mm)

Bolts tighten from above the plate and allow self-centering for easy installation and inspection

Multi-use pin design allows for temporary & permanent installations

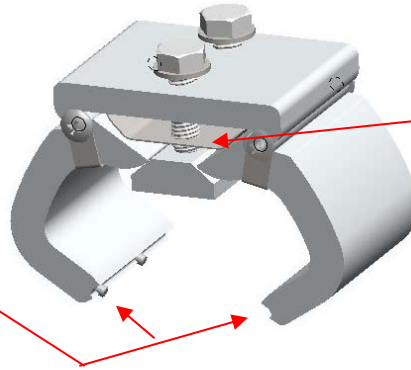

Spring-loaded mechanism keeps clamp open during installation

Membrane/Built-up Roofing Design

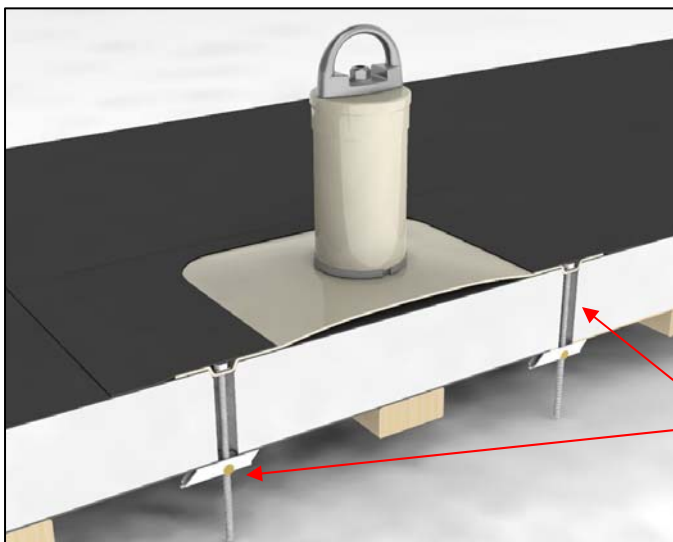

- Models available for built-up roof thicknesses accommodate up to 10.5 inches (267 mm)

Easy-to-install toggle kit fastens through membrane, insulation and into metal sheathing, wood sheathing or concrete

Q7: What connection devices are approved for use with the Miller Fusion?

A7: Miller shock-absorbing lanyards, self-retracting lifelines and rope grab/vertical lifeline systems are approved for use with the Miller Fusion. A competent person must carefully assess the work area and consider distance from an edge, potential swing-fall and the edge surface of the roof with which the connecting device may come into contact. Sharp edges should be padded and if the worker uses a cable self-retracting lifeline (SRL), a Miller SofStop® Shock Absorber pack (928LS) should be attached between the back D-ring of the worker's harness and the SRL.

Q8: Can the Miller Fusion be installed on other non-roof structures?

A8: Models for steel decking, concrete and wood can be installed on other non-roof structures. The structure to which the roof post is attached must meet all requirements set-forth in the product instruction manual.

Q9: How much fall clearance must be added to accommodate the shock-absorbing action of the Miller Fusion?

A9: One foot of fall clearance should be added to the worker's fall clearance calculation. Please reference the product instruction manual for a full description of how to calculate fall clearance.

Q10: What force must be applied to activate the Miller Fusion?

A10: The activation force is set at 1,000 lbf (4.5 kN).

Q11: What is the maximum capacity of the Miller Fusion?

A11: The Miller Fusion is designed for one worker weighing up to 310 lbs. including clothing and tools.

Q12: What is maximum slope or roof pitch for the Miller Fusion?

A12: The Miller Fusion is designed for either flat or low slope (less than 4:12 pitch) roof structures. This guideline makes the assumption that the roof can be safely traversed by workers without needing constant force against the connecting device to maintain footing or balance. The Miller Fusion may be used on a roof structure with greater than a 4:12 pitch providing proper footing is maintained. Typically, applicable standards and/or site requirements will require systems such as toe boards for properly working on steep slope roof surfaces."

For additional information, contact Miller Technical Service



by Honeywell

▶ Ask the Expert ... Ask Miller.

800/873-5242
or 814/432-2118

Fax 800/892-4078
or Fax 814/432-2415

www.millerfallprotection.com